

## APPLICATION

Sandvik DC301R is a hydraulic, self-propelled drilling unit on a 4-wheel, oscillated drive carrier. It drills holes with a maximum recommended diameter of 64 mm (2 1/2") and a maximum practical length of 15 meters (50'), utilizing 25, 28 or 32 mm (1", 1 1/8" or 1 1/4") extension rods.

DC301R is a completely self contained drilling unit. It is easily maneuverable with good rough terrain capabilities. It is also easy to transport between job sites on a truck or on a trailer, or it can even be lifted by a helicopter.

DC301R is equipped with HL 300, hydraulic top hammer rock drill. The rock drill is mounted on an aluminium chain feed, which is attached to an articulated boom giving a drilling coverage of 10 m<sup>2</sup> (108 sq-ft). A 61 kW/2000 rpm (81 hp) diesel engine supplies power both for hydraulic pumps and for an on-board compressor. Several routine functions of DC301R, e.g. colaring and antijamming, are automatically executed by electronic controls.

For easy operation, good visibility and operator safety, DC301R is supplied with a radio remote control for drilling and boom movements. Thanks to the electronics, this unit has fewer levers which make it easy to use. For operator comfort DC301R is also equipped with a dust collection system, which gathers drilling dust from the hole into a plastic bag.

Typical applications for DC301R are foundation drilling, road cutting, trenching, occasional bolting and other special drilling applications. Therefore DC301R is most often used by construction contractors, mines and quarries, and the municipal sector. Due to its versatility DC301R is often included in the equipment fleet of rental houses as well.

## COVERAGE AREA

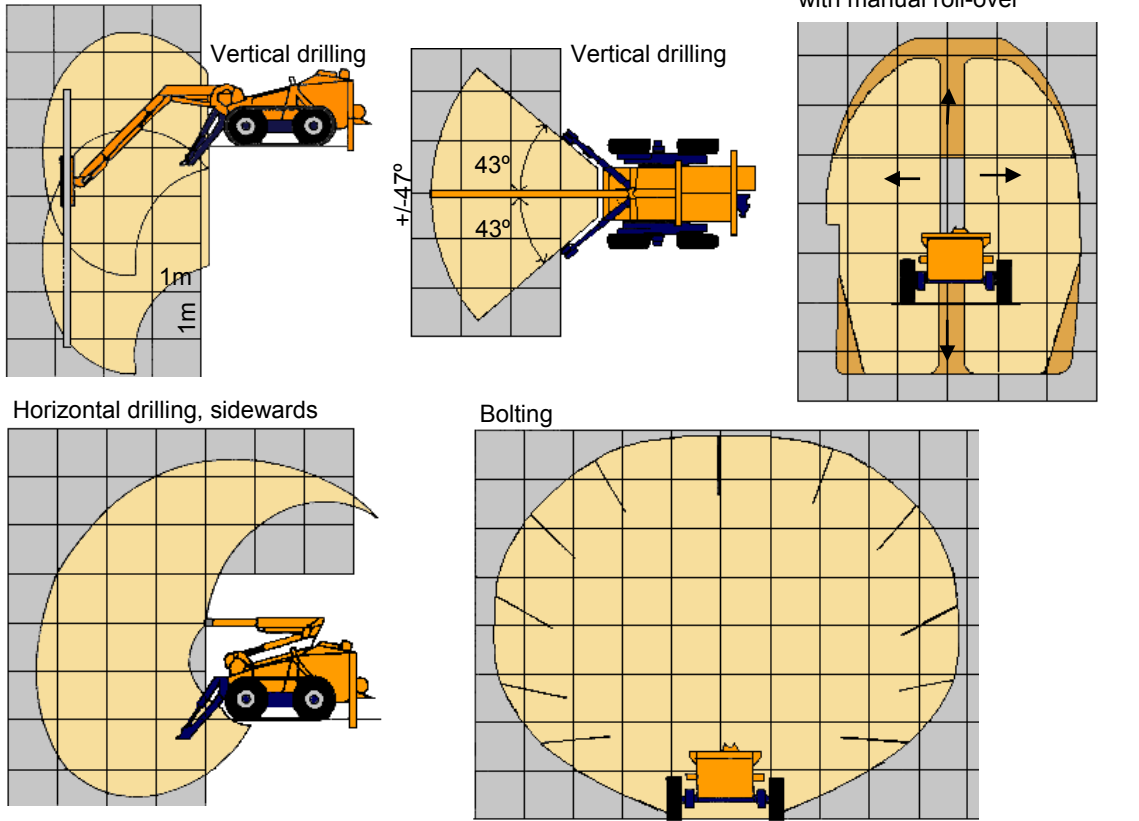

## DIMENSIONS

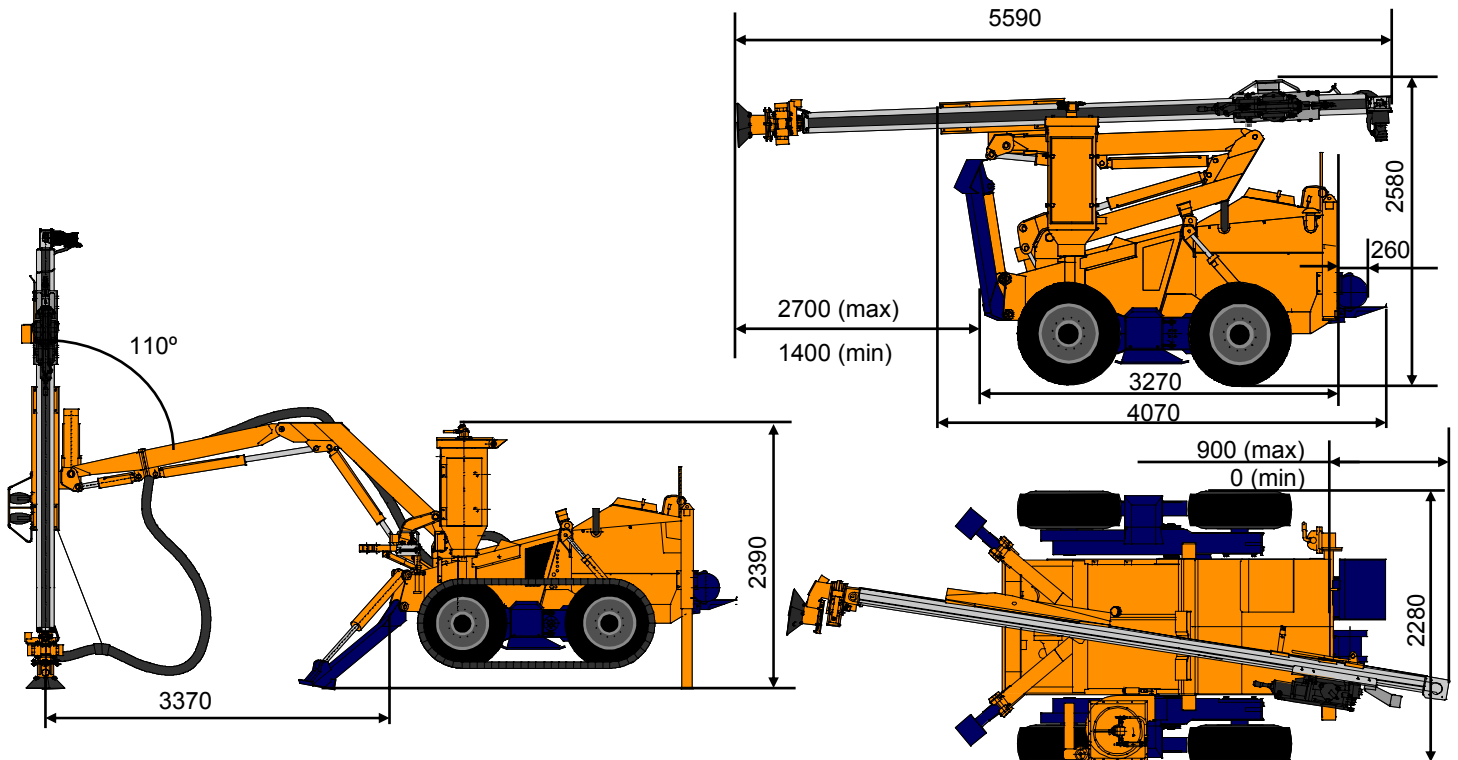

## STANDARD COMPONENTS

1. Rock drill HL 300, hydraulic
2. Chain feed CF 300 x 12/Pito 9H, incl. one set of jaws
3. Rod rack For 2 extra rods on chain feed
4. Boom DB 300, articulated
5. Carrier Rubber-tyred
6. Powerpack Diesel driven, hydraulic pumps and on-board compressor
7. Hydraulic system Open center and load sensing
8. Control system TA 342, Radio remote for drilling and boom movements
9. Dust collection system DC 410H, hydraulic
10. Working lights 4 pcs
11. Hydraulic jacks 4 pcs
12. Manuals Service and spare parts manuals:  
2 x paper copy  
2 x CD-ROM (Toolman)
13. EU-safety devices

## TRANSPORT DIMENSIONS

Weight (without options)	5 300 kg
Width without tracks	2.3 m
Height	2.6 m
Total length	5.6 m

## THE JAWS FOR DRILL STEELS

	Drill steel type	Drill steel diameter	Recommended hole diameter
1.	Hexagonal rod for HEX 1 drifter	22 mm 7/8"	28 - 45 mm 1 7/64" - 1 3/4"
2.	Extension rods	25 mm 1"	38 - 45 mm 1 1/2" - 1 3/4"
3.	Extension rods	28 mm 1 1/8"	38 - 48 mm 1 1/2" - 1 7/8"
4.	Extension rods	32 mm 1 1/4"	45 - 64 mm 1 3/4" - 2 1/2"

If several jaws selected please specify jaws assembled.

## SELECTION OF OPTIONS

1. HEX 1 rock drill (replaces standard component)
2. Hydraulic winch (2 tons)
3. Pulling device for 22 mm (7/8") rods
4. Chain tracks
5. Hydraulic drill steel grinder, Dynaset
6. Hydraulic drill steel grinder for integral steels, Sanroc RG100H
7. Angle indicator MEC Angie
8. TIM 2104 Tamrock inclination angle measuring and controlling system
9. Electric filling pump for refuelling
10. Electric engine heater
11. Spirit level angle indicator
12. Hydraulic roll-over (360°) boom head  
Specify the boom head dead point  
- upwards  
- 3 o'clock from front
13. Bigger rotation motor (400 Nm) for 51 or 64 mm holes
14. PTX exhaust gas purifier
15. Water flushing kit without water pump
16. Water pump for water flushing kit
17. Extra manuals
18. First service kit for DC301R, ID 551 623 25
19. Special tools for HL 300 field kit, ID 881 537 69

Sandvik Mining and Construction reserves the right to change this specification without further notice.